

INSTALLATION INSTRUCTIONS
FOR
THE B & C SPECIALTY PRODUCTS
STANDBY ALTERNATOR SYSTEM
IN
CESSNA MODEL 182 AIRCRAFT

DOCUMENT NO. T182SA-3



Rev. 3

Date: 07/11/2008

Completed By: Jason K. Moorefield
Director of Avionics, BS

Virginia Aviation
970 Airport Road
P.O. Box 4209
Lynchburg, Va. 24502
434-237-8420

Log of Revisions

Revision	Page	Description	*FAA Approved	Approval Date
IR	All	Initial Release		
1	6	Positioning of alternator		
1	7	Location of MCU and Annunciator		
1	14	Clearance from firewall to Alternator		
1	16	Added location of existing hole		
1	19	Added location of bulkhead for reference		
1	22	Added reference to measure for annunciator		
1	24	Added reference to measure for annunciator		
1	All	Misc Grammatical errors		
2	All	Various		
3	All	Various due to installation conformity		

Table of Contents

- I. Introduction
- II. Description
 - A. Physical Description
 - B. Specifications
- III. Parts List
- IV. Installation
- V. Checkout Procedure
- VI. Instructions for Continued Airworthiness
- VII. Appendix A
- VIII. Appendix B

I. Introduction

The BC425 Standby Alternator and the BG203-2D Voltage Regulator are manufactured by B & C Specialty Products. These two products comprise the system that can be installed using this installation manual. Pertinent product information to aid in installation and troubleshooting for this Standby Alternator System can be found by accessing the B& C website at URL <http://www.bandcspecialty.com> or <http://www.virginiaaviation.com>.

The Standby System provides up to 20 amps of power to support continued flight in the event that the aircraft primary source of power has failed. The system operates automatically utilizing a sensing device that turns on the Standby Alternator when the Bus voltage begins to drop. In the event of aircraft primary alternator failure, Bus voltage would drop from 28 VDC to 24 VDC reflecting only the battery potential. It is this drop in Bus voltage that would trigger the automatic operation of the BC425 alternator.

II. Description

A. Physical Description

Figure 1 in Appendix A depicts the physical characteristics of the BC425 Alternator for the side and front view. Figure 2 shows the rear view of the standby alternator and the cutout dimensions for the annunciator. Figure 3 displays the physical characteristics of the voltage regulator and gives the function for each of the terminal posts.

B. Specifications – BC425 Standby Alternator

Output	20 Amps
Weight	5.72 lbs.
BC203-2D Weight	0.6 lbs.
Voltage	14/28 VDC
Stator Temp	140 to 210 Deg F
Max Stator Temp	300 Deg F

III. Parts List

This parts list is included in Kit P/N 425-502-1 or equivalent.

ITEM	UNLESS OTHERWISE SPECIFIED			
	USED ON		PART NUMBER	DESCRIPTION
		QTY		
1		1	BC425-1	ALTERNATOR
2		1	BC203-2D	REGULATOR
3		1	218-2	CURRENT SENSOR
4		1	700-001-40	BREAKER, 40 AMP
5		1	MS24509-A-5	BREAKER, 5 AMP, TOGGLE TYPE
6		1	7277-2-1	BREAKER, 1 AMP
7		1	425-205-1	ANNUNCIATOR
8		1	425-403	PLACARD, BREAKER, SENSE
9		1	425-402	PLACARD, BREAKER, STBY ALT
10				
11		4	MS24693-S26	MACHINE SCREW, FLAT HEAD
12		4	AN960-6	WASHER, FLAT
13		4	MS21042-06	NUT, HEX, LOCK
14		2	MS9134-01	GASKET
15		1	425-401	SWITCH PLACARD
16		1	410-401	"IF FLASHING REDUCE LOAD" PLACARD
17		1	MS25171-2S	INSULATOR, SILICON
18		10	M22759/16-20-9	WIRE, 20 AWG
19		25	M22759/16-22-9	WIRE, 22 AWG
20		8	S814R6	RING TERMINAL, #6
21		2	MS21919-WDG2	CLAMP, CUSHIONED
22		20	MS3367-1-9	CABLE TIE, NYLON
23		2	MS35214-14	SCREW, PAN HEAD, 6-32 x .38, BLACK
24		1	425-206	FIELD CONNECTOR ASSEMBLY
Note: Procure the following parts, which are not supplied with the Standby Alternator kit.				
		5	MS22759/16-10	5 FT. OF 10 GAUGE WIRE
		1	320569	AMP YELLOW ¼" RING TERMINAL
		5	320568	RING TERMINAL YELLOW 12-10 #6
		1	MS35489-9	RUBBER GROMMET

IV. Installation

The BC425-1 Alternator is installed on the lower right AND20000 (Vacuum Pump) accessory drive pad of the Lycoming IO-540-AB1A5 engine. Illustration I of App. B shows a pictorial view of the cover plate installed on the drive pad and Illustration II shows the alternator installed in that same position.

In preparation for the installation the following steps should be taken:

1. Remove the left and right halves of the engine cowling
2. Disconnect the Aircraft Battery
3. Refer to appropriate Lycoming overhaul manual. Remove the cover plate from the lower drive position of the accessory case. Determine whether the accessory drive gear is installed here or whether the bearing is plugged. If the bearing is plugged, remove the engine accessory case and install the accessory drive gear and thrust washer in the lower accessory drive position. Once the gear is installed, re-assemble accessory case to engine. If the gear is installed proceed to next step and disregard additional parts. Parts necessary for the gear installation application are as follows:

Lycoming Part Number LW-10313 – Gear

Lycoming Part Number 71596 – Washer

Lycoming Part Number 06A19956 – Seal

Proceed with the installation as follows:

1. If the gear above is installed or once the installation is complete, clean the gasket surface well with suitable cleaner and install the alternator onto the accessory pad with a new gasket (Item 14), 4 Nuts (Item 13), 4 lock washers (MS35333-40) and flat washers (Item 12). Torque the nuts 90 to 110 inch-lbs. The alternator can be clocked to any position that facilitates the connection of wires and ease of securing the bolts.
2. The wiring from the alternator to the Master Control Unit (MCU) and Alternator controller/voltage regulator is routed through an existing hole in the firewall. If provisions for a hole are not found, then contact your local FAA office to obtain approval for drilling a hole in the firewall. Install an aircraft approved grommet P/N MS35489-9. Seal the grommet with High Temperature RTV #736. Ty-Wraps P/N MS3367-1-9 Item (item 22) should be used to secure harness as required to route from alternator to location of firewall grommet. Reference Figure 5, Illustration III, and Illustration IV in App. B for grommet location and installation.
3. Route the 20 gauge field wire and the three color coded current sense wires to the location of the Standby Alternator Controller BC203-2D. Route the 10 gauge wire from the current sensor (installed in supplied harness and shrink wrapped for protection) to the location of the 40 amp circuit breaker. Reference Illustration VII and VIII for circuit breaker location. Install the supplied 10 gauge wire segment part of (item 3) that will be terminated to the load side of the 40 amp breaker on the Alternator feed post and protect with an insulator (item 17). Route the 20 gauge wire from the “STBYALT” Field Switch to the location of the Controller. Route the additional 10 gauge wire from the line side of

the 40 amp Circuit breaker to the post on the Master Control Unit (MCU) P/N 83100-344 to be terminated later in this document. Reference Illustration V for location of MCU and Figure 5 for routing of this wire from alternator to MCU. The additional 10 gauge wire is routed through the existing tubing that is indicated by the black arrow in Illustration V or it can be secured using ty-wraps (item 22) as described in Figure 5.

4. Install the BC203-2D Alternator Controller on the LH side of the fuselage aft of the firewall using 4ea. 8-32 screws, 4ea. MS21042-08 nuts and 4ea. AN960-8 washers. Reference Figure 6 and Illustration VI for the location and installation orientation of the Controller/Regulator. The Alternator Controller is mounted 6in (+/- 1/2in) from the bottom of the instrument panel and 1in (+/- 1/4in) forward of FS 17.5.
5. Reference Illustrations VII and VIII for the installation of the circuit breakers. Two plug buttons are installed on the inboard side of the CB panel adjacent to the row of circuit breakers labeled Electrical Bus 2. Remove the Circuit Breaker Panel overlay to gain access the Instrument panel structure for circuit breaker installation. Install supplied 40 amp circuit breaker and 1 amp sense breaker in locations as shown in Illustrations. Re-install CB panel overlay and install 425-402 placard above 40 amp CB and 425-403 placard above 1 amp circuit breaker.
6. Reference Illustration X in App. B for location of STBY ALT field switch into an existing hole on the lower LH side of the instrument panel. Remove the switch panel assembly screws and secure the panel to prevent damage to existing wiring. Install the MS24509-A-5 switch in location shown and place 425-401 switch placard above the switch as depicted in Illustration X. Leave the switch panel as is until annunciator is installed in the next step.
7. Reference Illustrations IX and XI for the installation of the 425-205 Annunciator. The Annunciator is mounted approximately 15/16in (+/- 1/8in) from the edge of the PFD panel cutout as depicted by the RED arrow in illustration IX. The Annunciator is mounted approximately 2in (+/- 1/8in) from the bottom of the top left instrument panel screw as depicted by the RED arrow in figure XI. Then Utilizing the drawing shown in Figure 2 for the Annunciator Cutout cut hole install the annunciator. Ensure that the Glareshield does not obstruct the pilot's view of the annunciator. Re-install switch panel assembly only after all wiring terminations have been completed according to Figure 4. Place 410-401 placard for the annunciator in the vicinity of the STBY ALT switch as depicted in Illustration X.

Proceed with Wiring harness termination to all components as follows:

8. Terminate supplied 10 gauge wire segment from current sensor to the load side of the "STBY ALT" 40 amp CB. Terminate added 10 gauge wire segment to the line side of the same CB. Terminate 20 gauge sense wire and 22 gauge wire from annunciator to load side of the "STBY ALT SENSE" 1A CB. Attach the line side of the 1A CB to the line side of the 40 amp circuit breaker with a jumper made of 10 gauge wire and two added 320568 terminals.
9. Terminate added 10 gauge wire segment at the MCU to post depicted by white arrow in Illustration V also reference Figure 5 for location of post.

10. Terminate all wiring routed to component locations in the installation instructions per Figure 4. Reference Figure 3 for terminal post location and definition of the Standby Alternator Controller terminal posts.

V. Checkout Procedure

11. Perform preliminary and final operational checks of the system per VA Aviation drawing number T182SA-2.

VI. Instructions for Continued Airworthiness

12. Reference B&C documents ICA-BC425 and ICA-BC203-2D for any pertinent instructions. It is recommended that alternator, controller and all associated wiring be inspected during annual or 100 hour inspections. The BC425-1 Alternator requires no recurrent maintenance. However, B & C Specialty Products recommends that the unit be returned to B & C Specialty's facility for overhaul after the unit has reached approximately 1700 hours of service.

Note: All work performed in this Installation Guide should comply with directions set forth in AC 43:13-1B.

VII. Appendix A

Drawing of Standby Alternator

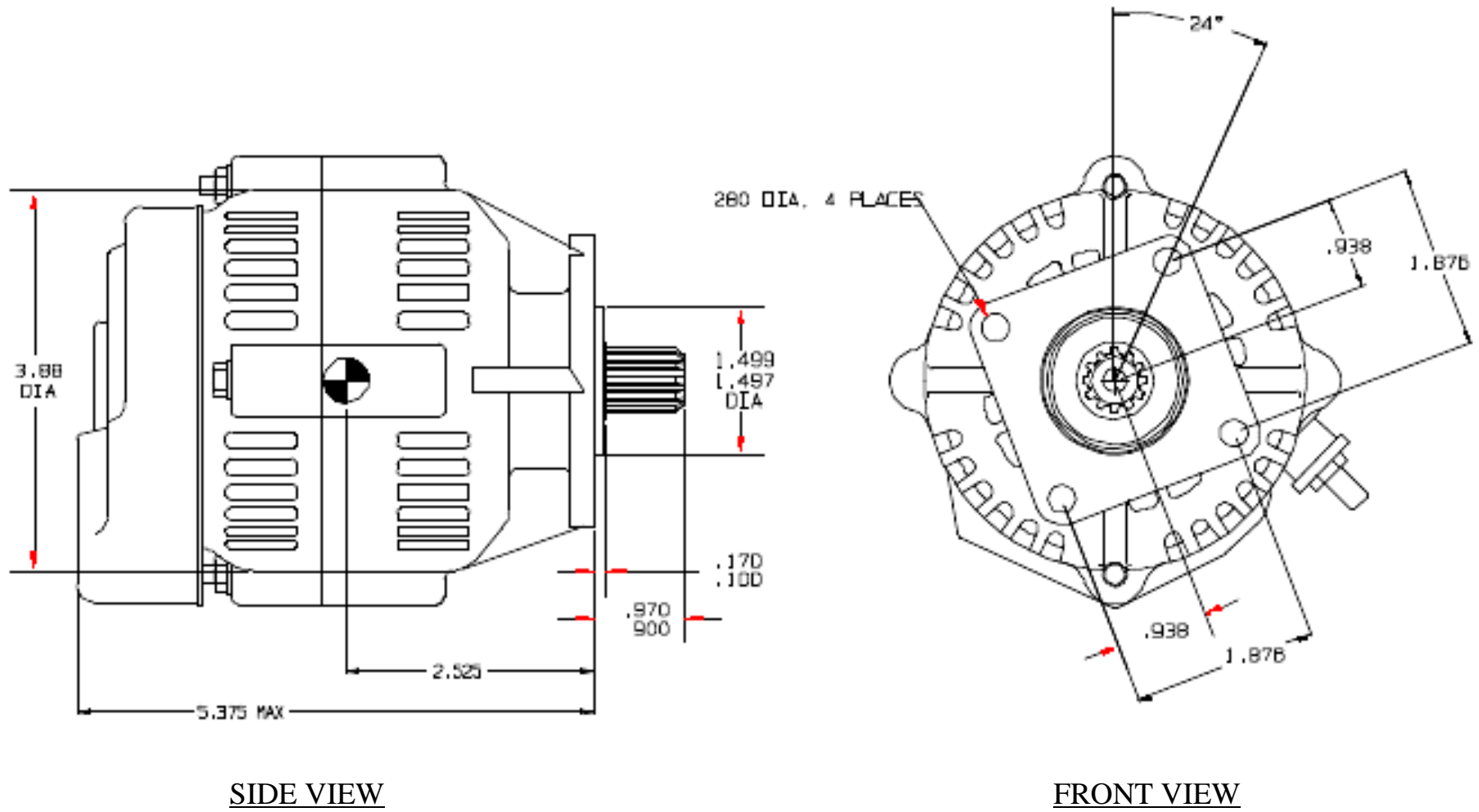
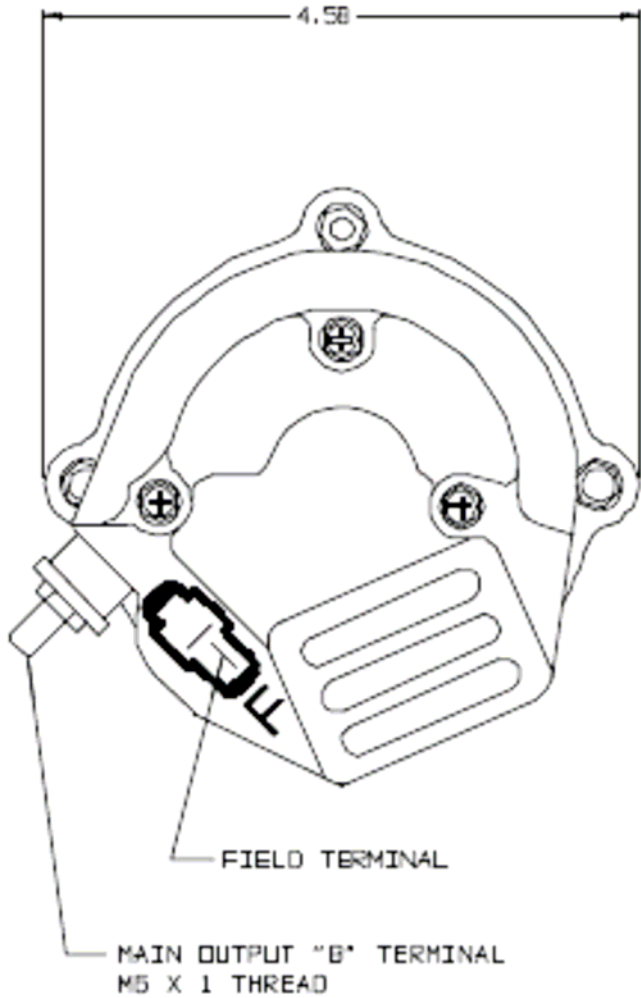

FIGURE 1

Rear view of Standby Alternator Controller



REAR VIEW

Drawing of Hole in Instrument Panel for Annunciator

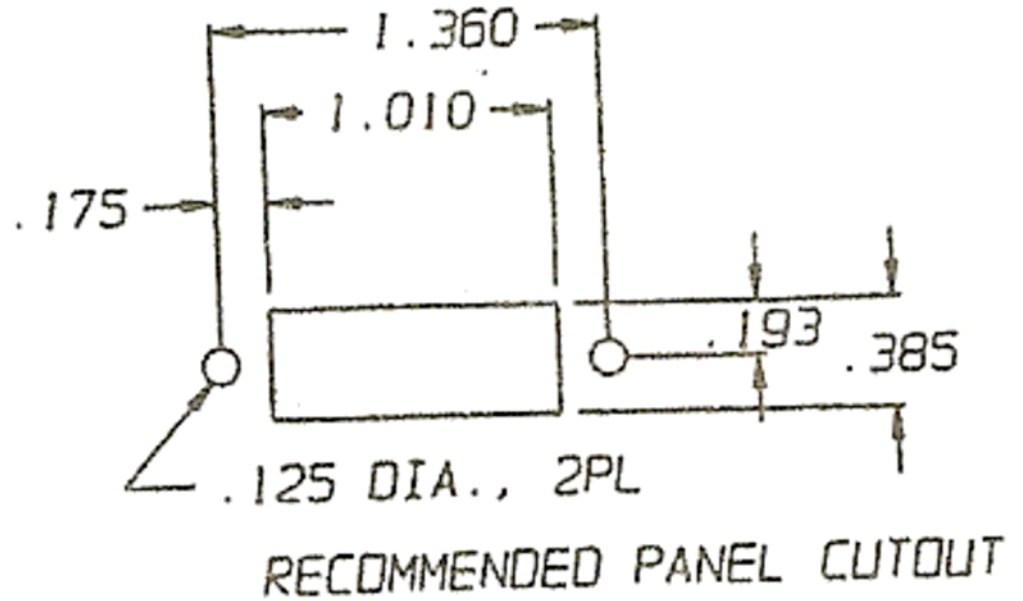

ANNUNCIATOR CUTOUT

FIGURE 2

Standby Alternator Controller Physical Dimensions and Terminal Functions

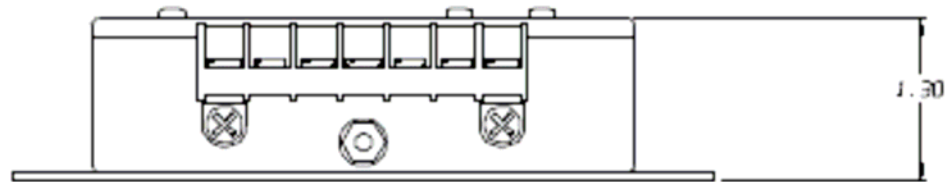
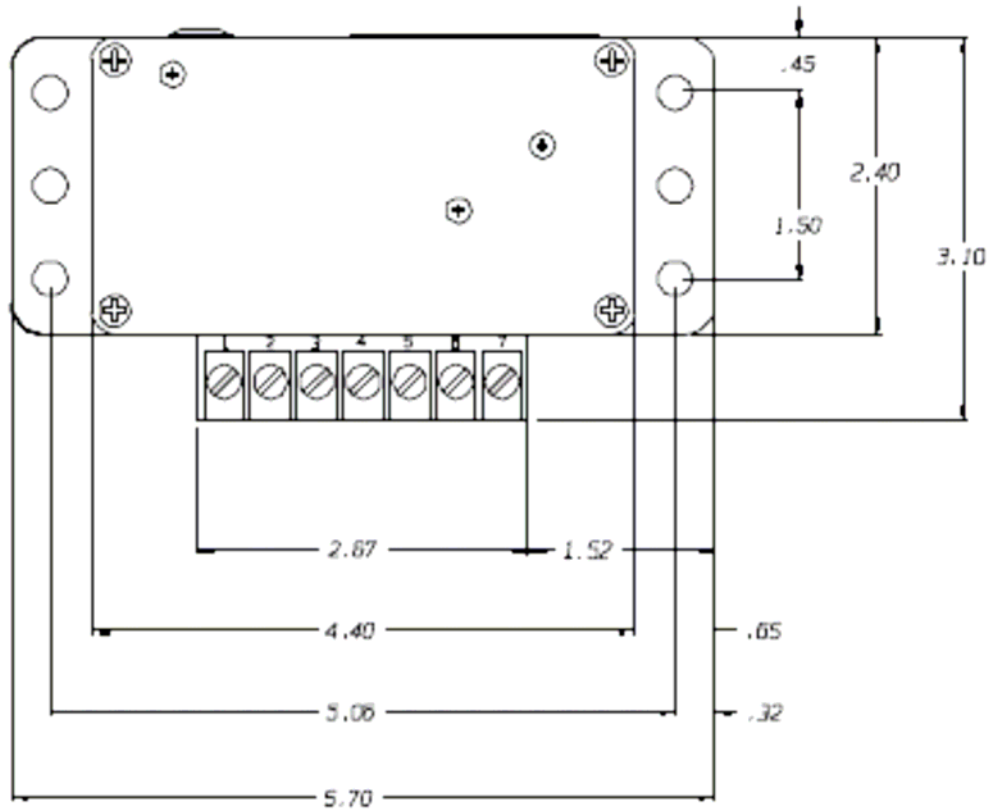

TERMINAL FUNCTIONS (-2): (STANDBY CONTROLLER)

1. BUS SENSE
2. STBY ALT ON ANNUNCIATOR
3. CURRENT SENSOR ANALOG (OPTIONAL)
4. CURRENT SENSOR +10 VOLTS (OPTIONAL)
5. FIELD
6. BUS SUPPLY
7. GROUND

FIGURE 3

Wire routing inside engine compartment from Standby Alternator to MCU

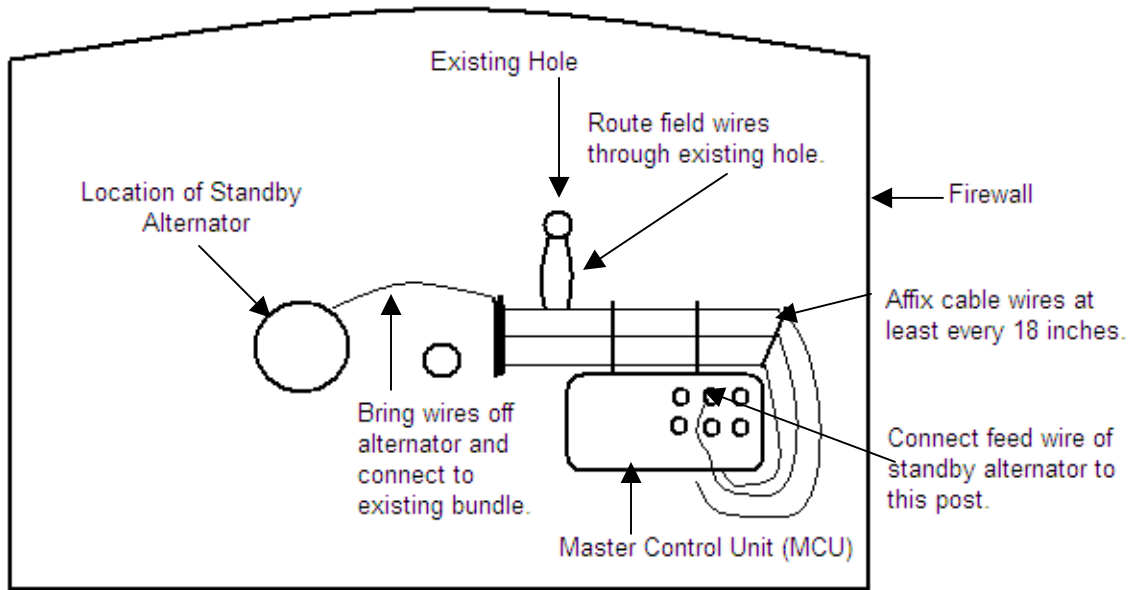

Figure 5

Drawing of Alternator Control Unit Installation

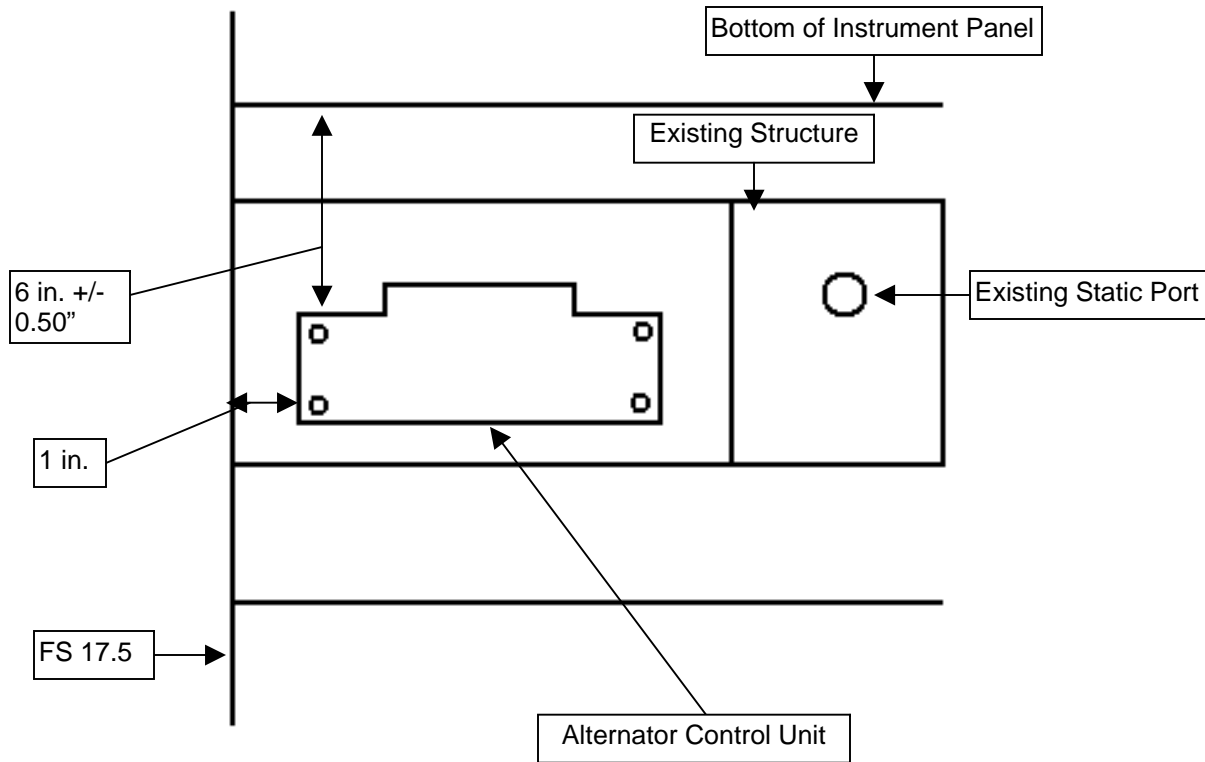

Figure 6

VIII. Appendix B

Illustration of AND20000 Drive Pad Prior to Alternator Installation



Illustration I

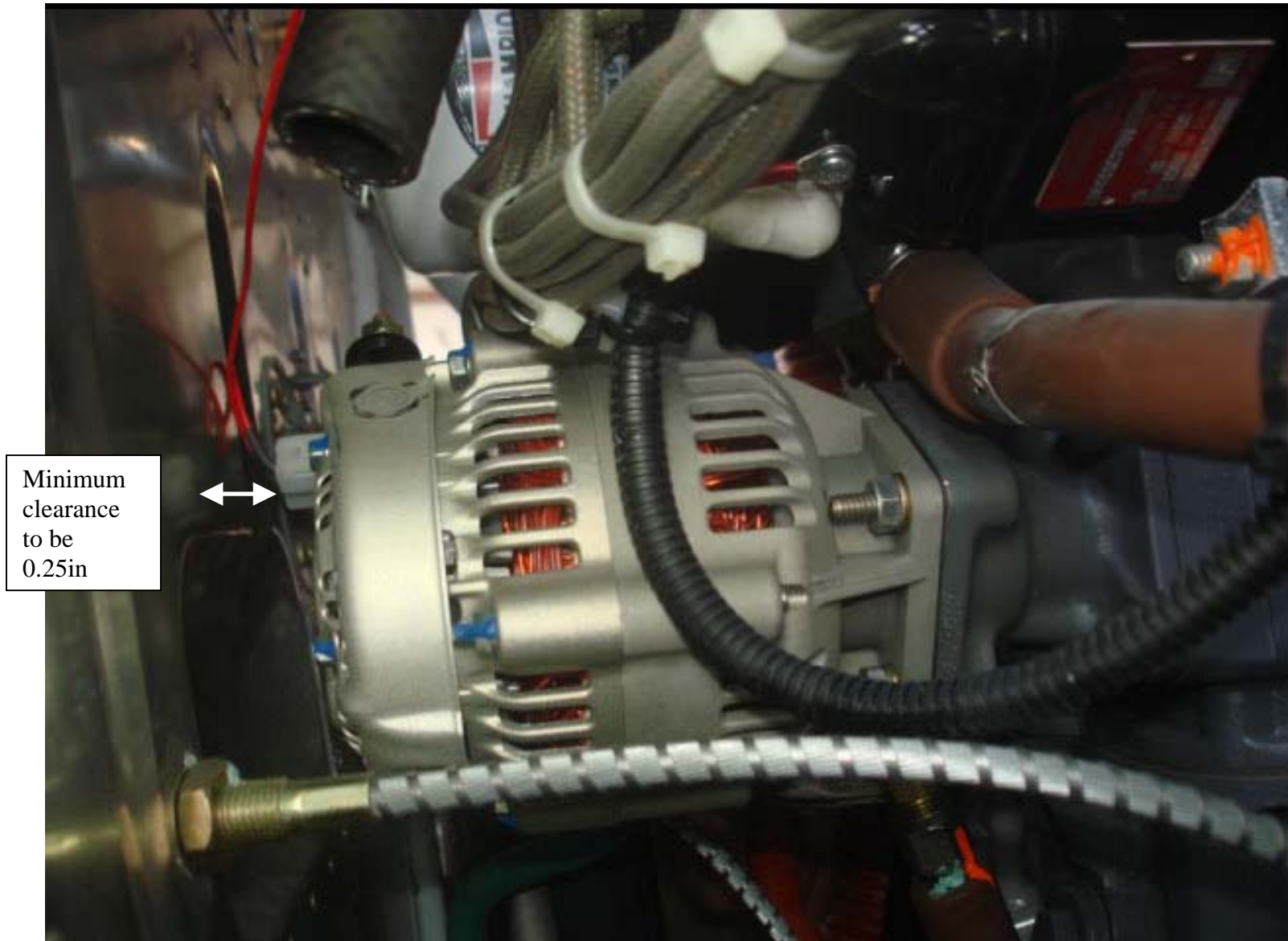

Illustration of AND20000 Drive Pad with Alternator Installed

ILLUSTRATION II

Existing hole through the firewall is the old Tachometer Cable hole. If this hole is not present contact your local FAA office for approval to make a new hole in the firewall.



ILLUSTRATION III

Illustration of Wiring for Standby Alternator Routed through the hold and Grommet installed. Seal Grommet with RTV# 736.

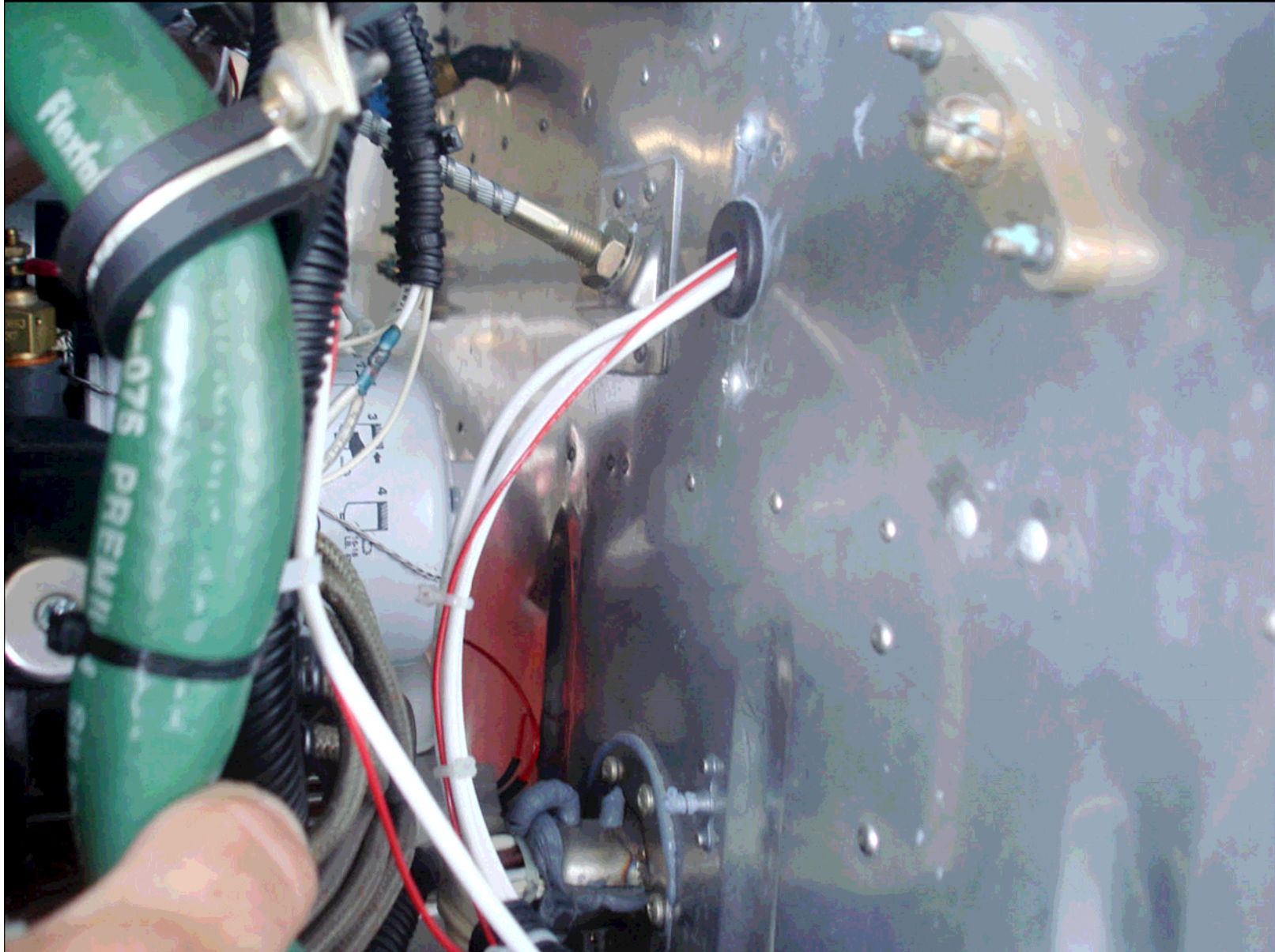

ILLUSTRATION IV

Illustration of Master Control Unit (MCU) white Arrow indicates location of Standby Alternator 10 gauge Feed wire. Black Arrow indicates the existing tubing that the 10 gauge feed wire may be routed through.

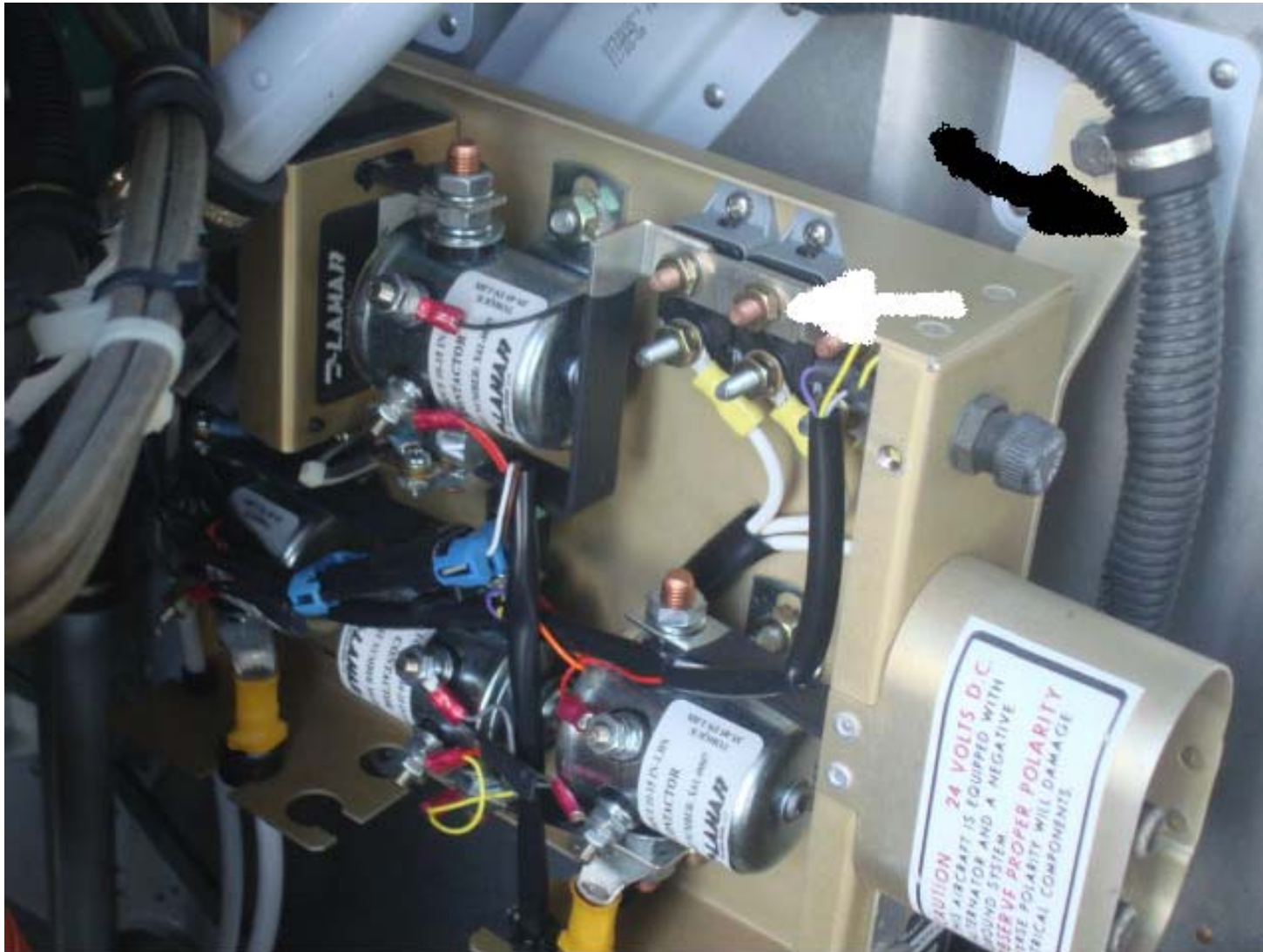

ILLUSTRATION V

The Alternator control unit installed on the lower left side of the aircraft just beneath the instrument panel and forward of FS17.5.

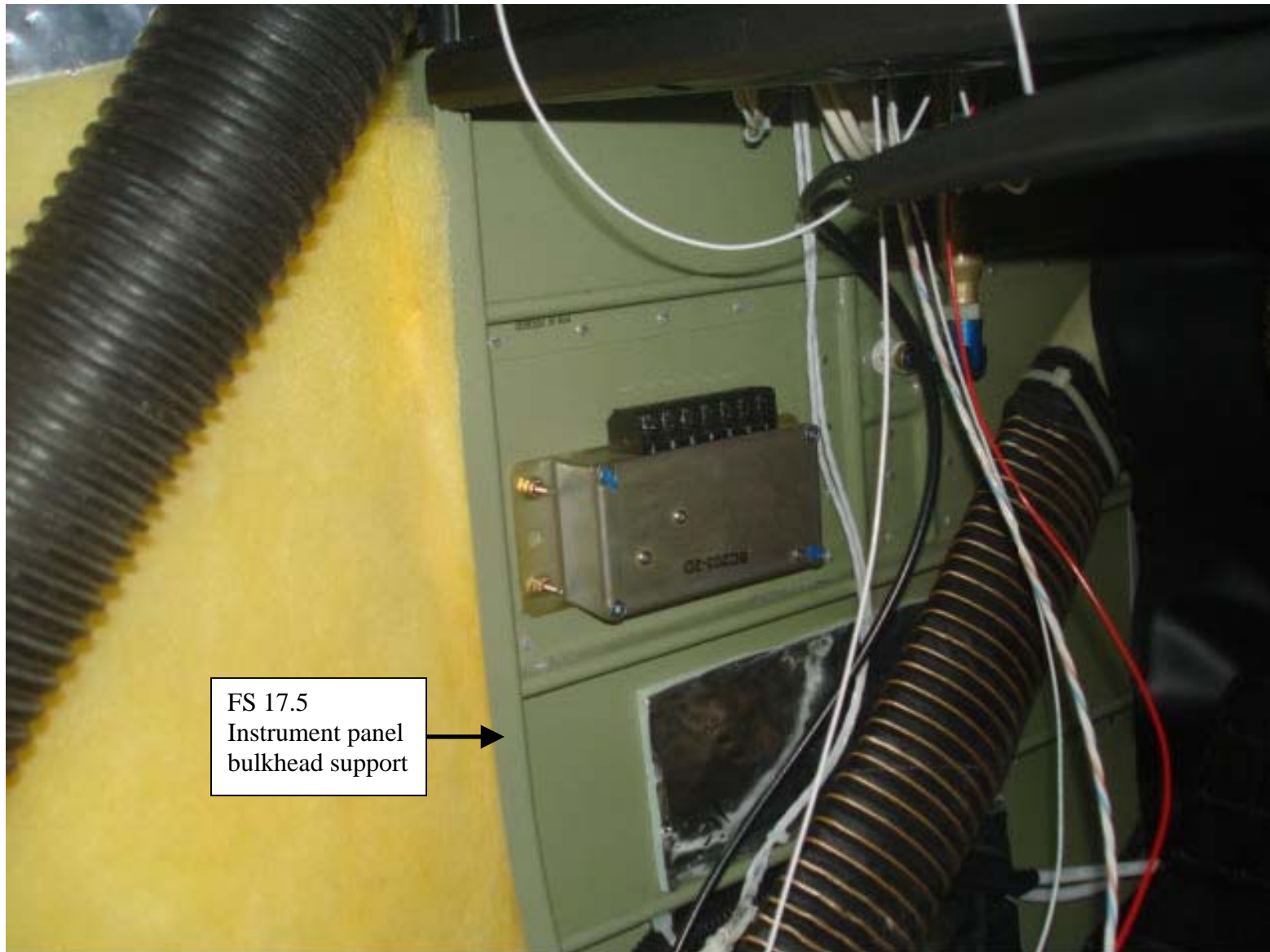

ILLUSTRATION VI

Existing Circuit Breaker Holes for Standby Alternator Circuit Breakers.



ILLUSTRATION VII

Circuit Breakers are installed and Labeled



ILLUSTRATION VIII

Location of the Amber STBY ALT ON Annunciator – Measure 15/16 in (+/- 1/16) from the PFD cutout as depicted by the Red Arrow. Reference figure 2 for the annunciator cut-out.



ILLUSTRATION IX

Location of the Installed “STBY ALT ON” Switch and the Placard P/N 410-401.



ILLUSTRATION X

“STBY ALT ON” annunciator is installed in the instrument panel. The Annunciator is mounted approximately 2in (+/- 1/8in) from the bottom of the top left instrument panel screw as depicted by the RED arrow. Reference figure 2 for Annunciator cut-out.



ILLUSTRATION XI